



**SPECIFICATIONS**

Rated Current:3.0AMP  
 Contact Resistance:20mΩ Max  
 Withstand Voltage:1000V AC/DC  
 Insulation Resistance:1000MΩ Min  
 Operation Temperature:-40°c to +105°c

Contact Material:Brass  
 Contact Plating:Au or Sn Over Ni  
 Insulator Material:Polyester(UL94V-0)  
 Standard: PA6T

Max.Processing Temp: 230°C for 30-60 seconds  
 (260°C for 10 seconds)

Recommended P.C.B Layout(Top Side)  
 (PCB BOARD TOLERANCE±0.05)

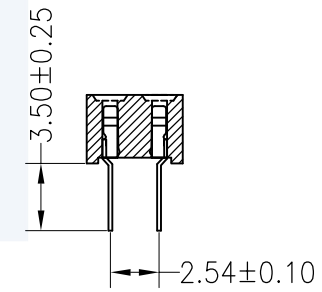
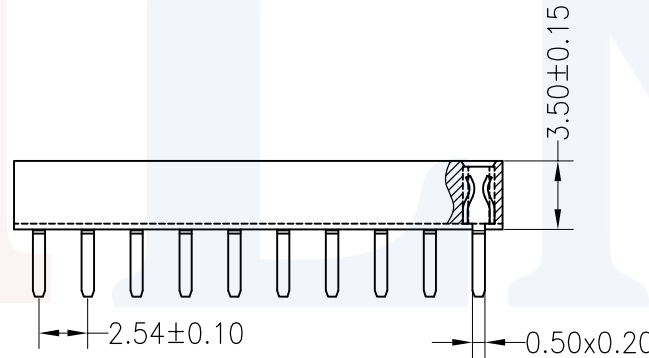
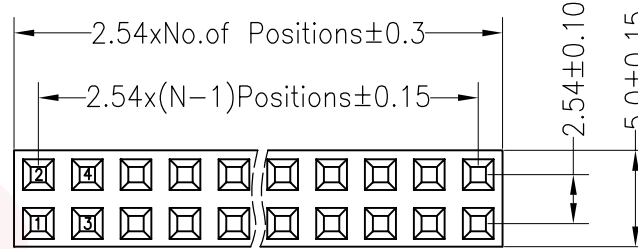
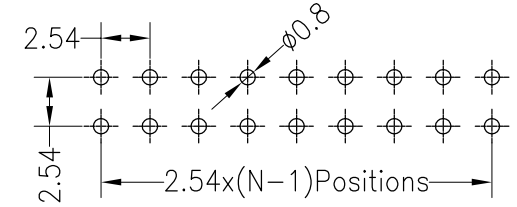

**Ordering Information**

2235 02 XX X N XX S U X 01

No.of Pins Per Row 2\*40

Insulator Material Option  
 A=BK-PBT  
 C=BK-PA6T  
 D=BK-PA46  
 E=BK-PA9T  
 F=BK-LCP

Contact Plating  
 G1:1U" Gold  
 G2:1.5U" Gold  
 G3:2U" Gold  
 G4:3U" Gold  
 G5:5U" Gold  
 G6:10U" Gold  
 G7:15U" Gold  
 S0:Gold Flash/Tin  
 SN:Tin

Packing  
 A=Tray  
 T=Tube  
 P=Tube+Cap  
 O=PE Bag  
 R=Reel+Cap  
 M=Mylar+Reel

		OPERATION		DRAW	YiYuSheng	12.03.28	SCALE	FIT	<b>JILN</b> ® 深圳市锦凌电子有限公司 SHENZHEN JINLING ELECTRONIC CO.,LTD Tel: 86-755-2997-5806/5802 Fax: 86-755-2997-5992	
		X.X	±0.30				UNIT	mm		
				CHECK			SIZE	A4	PART NO. 223502XXXNXXSUX01 TITLE: 2.54PF H3.50mm 2xNpin 180°	
		X.XX	±0.20		SHEET	1/1				
				APPROVE			PROJ.			
		X.XXX	±0.10		Angle	±3°				
				DIM	TOL					

REV	DATE	MODIFICATION DESCRIPTION	CHANGE
A0	2012.03.28	NEW DRAWING	