

# HSF RoHS

## SPECIFICATIONS

Rated Current:5.0AMP  
 Contact Resistance:20mΩ Max  
 Withstand Voltage:1000V AC/DC  
 Insulation Resistance:1000MΩ Min  
 Operation Temperature:-40°C to +105°C

Contact Material:Phosphor Bronze  
 Contact Plating:Au or Sn Over Ni  
 Retention LEG:Copper Alloy  
 Retention LEG Plating:Tin Over Ni  
 Insulator Material:Polyester(UL94V-0)  
 Resistance To Soldering Heat:  
 245° C±5° C, 10s(PBT insulator)  
 260° C±5° C, 10s(PA6T&PA9T&LCP insulator)

Recommended P.C.B Layout(Top Side)  
 (PCB BOARD TOLERANCE±0.05)

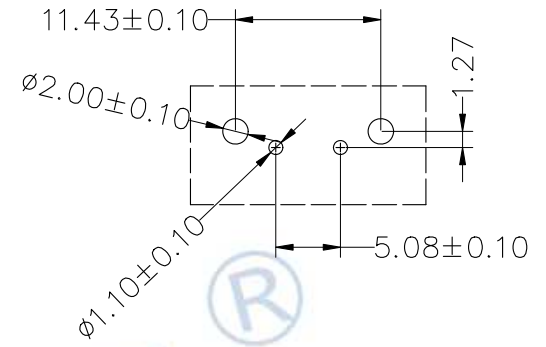
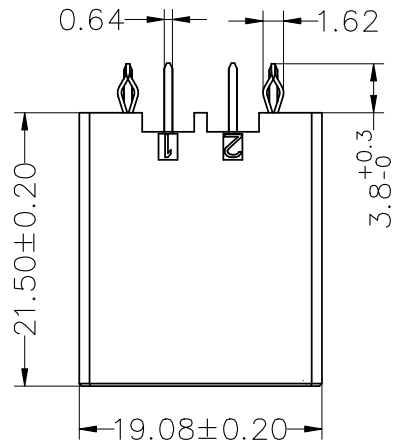

## Ordering Information

8600-1 02 XX A B 0 X

No.of Pins  
1x2P

Contact Plating  
 G0:Gold Flash  
 G1:3U" Gold  
 G2:5U" Gold  
 G3:10U" Gold  
 G4:15U" Gold  
 G5:30U" Gold  
 S0:Gold Flash/Tin  
 SN:Tin  
 SM:Matte-Tin

Insulator Material  
 Option  
 A=BK-PBT  
 B=BK-PA66  
 C=BK-PA6T  
 D=BK-PA46  
 E=BK-PA9T  
 F=BK-LCP

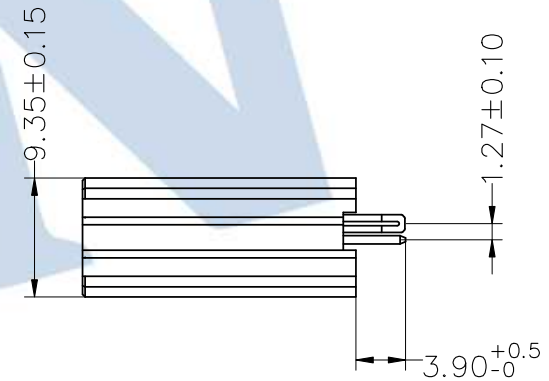
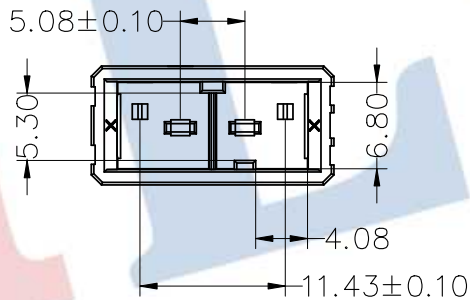

				OPERATION		DRAW	YiYuSheng	18.10.31	SCALE	FIT	<b>JILN</b> ® 深圳市锦凌电子有限公司 SHENZHEN JINLING ELECTRONICS CO.,LTD Tel: 86-755-27483253 Fax: 86-755-2997-5588	
				X.X	±0.30				UNIT	mm		
				CHECK		APPROVE			SIZE	A4	PART NO.	8600-102XXABOX
A0	2018.10.31	NEW DRAWING		X.XXX	±0.10				SHEET	1/1	TITLE:	单排2Pin针座
REV	DATE	MODIFICATION DESCRIPTION		CHANGE	DIM	TOL	APPROVE	PROJ.	客户规格:	A型单排2芯公针(1-917337-5)		