



SPECIFICATIONS

Rated Current:3.0AMP
 Contact Resistance:20mΩ Max
 Withstand Voltage:1000V AC/DC
 Insulation Resistance:1000MΩ Min
 Operation Temperature:-40°c to +105°c

Contact Material:Brass
 Contact Plating:Au Over Ni
 Insulator Material:Polyester(UL94V-0)
 Resistance To Soldering Heat:
 260° C±5° C, 10s(PA6T&PA9T&LCP insulator)

Recommended P.C.B Layout(Top Side)
 (PCB BOARD TOLERANCE±0.05)

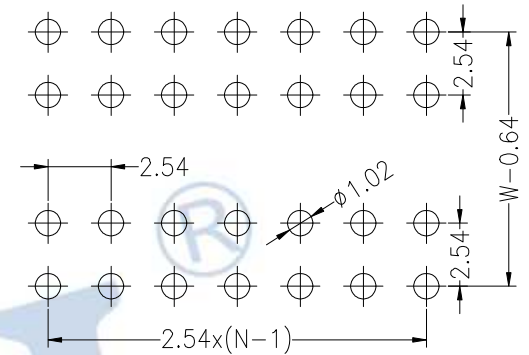
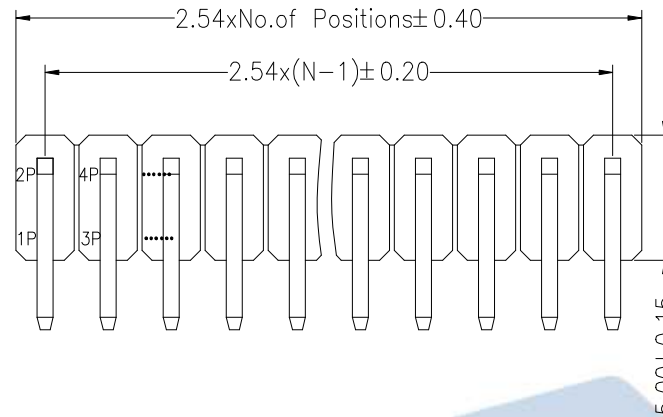

Ordering Information

12XX 12 XX X N XX U XXX X 0X

- High.of Plastic
10=H1.0mm
15=H1.5mm
17=H1.7mm
20=H2.0mm
25=H2.5mm
30=H3.0mm
33=H3.3mm
- No.of Pins Per Row
02~40P
- Insulator Material Option
C=BK-PA6T
E=BK-PA9T
F=BK-LCP
- Contact Plating
G0:Gold Flash
G1:1u" Gold
G2:1.5u" Gold
G3:2u" Gold
G4:3u" Gold
G5:5u" Gold
G6:10u" Gold
G7:15u" Gold
G8:30u" Gold
S0:Gold Flash/Tin
SN:Tin
- Pin Length
- Packing
0=PE Bag
A=Tray
T=Tube
P=Tube+Cap
R=Reel+Cap
M=Reel+Mylar

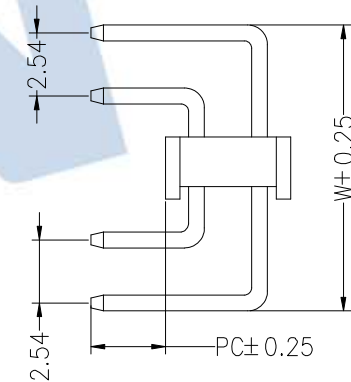
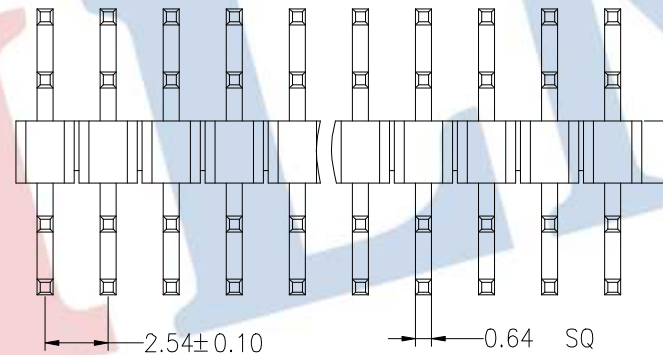

胶芯居中

Dimension antitheses list		
ITEM	PC	W
Alternate	XXX	XXX

		OPERATION		DRAW	RICH LIN	23.06.10	SCALE	FIT
A0	2023.06.10	NEW DRAWING						
REV	DATE	MODIFICATION DESCRIPTION	CHANGE					

JILN 深圳市锦凌电子有限公司
 SHENZHEN JINLING ELECTRONICS CO.,LTD
 Tel: 86-755-27483253 Fax: 86-755-2997-5992

PART NO.	12XX12XXXNXXUXXX0X
TITLE:	2.54mm Pin Header 两边弯